

2216 Nways Multiaccess Connector



Installation and Initial Configuration Guide

2216 Nways Multiaccess Connector



Installation and Initial Configuration Guide

Note

Before using this information and the product it supports, be sure to read the general information under Appendix C, "Notices" on page C-1 and safety information in Appendix D, "Safety Information" on page D-1.

Third Edition (June 1998)

This edition applies to the IBM 2216 Nways Multiaccess Connector Model 400.

Order publications through your IBM representative or the IBM branch office serving your locality. Publications are not stocked at the address given below.

A form for readers' comments appears at the back of this publication. If the form has been removed, address your comments to:

Department CGF
Design & Information Development
IBM Corporation
PO Box 12195
RESEARCH TRIANGLE PARK NC 27709-9990
USA

When you send information to IBM, you grant IBM a nonexclusive right to use or distribute the information in any way it believes appropriate without incurring any obligation to you.

© **Copyright International Business Machines Corporation 1997 1998. All rights reserved.**

Note to U.S. Government Users — Documentation related to restricted rights — Use, duplication or disclosure is subject to restrictions set forth in GSA ADP Schedule Contract with IBM Corp.

Contents

About This Guide	v
Who Should Use This Guide	v
About the Software	v
How to Proceed	v
2216 Library Overview	vi
Visit our Web Sites	ix
Information, Updates, and Corrections	ix
Product Support	ix
Chapter 1. Installing the 2216	1-1
Chapter 2. Problem Solving	2-1
LED Indicators	2-2
Power Supply Status	2-3
System Card Status	2-3
Adapter Card Status	2-3
Important Phone Numbers	2-4
Chapter 3. Accessing the 2216	3-1
Access Methods	3-1
Attaching an ASCII Terminal	3-3
ASCII Terminal Setup Attributes	3-3
Managing the Operational and Configuration Software	3-4
Chapter 4. Performing the Initial Configuration	4-1
Setting Up the Router (Initial Configuration)	4-1
After Initial Configuration	4-2
Full Configuration	4-2
Appendix A. Adapter Plugging Defaults	A-1
Plugging Sequences	A-1
Slots and Adapters	A-1
Appendix B. Common Tasks	B-1
LED States / Adapter Status	B-1
The Firmware Interface	B-1
Command Line Interface	B-1
Navigating Through the Command Line Interface	B-1
Displaying List of Configured Interfaces	B-2
Displaying the Operational State of the Interfaces	B-3
Verifying Connectivity	B-3
Viewing Vital Software Data	B-3
Viewing Vital Hardware Data	B-4
Adding an Adapter at Initial Configuration	B-4
Adding an Adapter after Initial Configuration	B-5
Running Quick Configuration	B-6
Disabling an Adapter Port	B-6
Enabling an Adapter Port	B-6
Suspend Traffic on an Adapter Port	B-6
Resume Traffic on an Adapter Port	B-7

Removing and Deleting an Adapter	B-7
Running Diagnostics	B-8
Up-to-Date IBM 2216 Information	B-8
Disabling Interfaces that Have WAN Reroute Enabled	B-8
Enabling WAN Reroute after You Have Disabled it	B-8
Remote File Download	B-9
Spare Interfaces	B-10
Appendix C. Notices	C-1
Notice to Users of Online Versions of This Book	C-1
Electronic Emission Notices	C-2
Trademarks	C-6
Appendix D. Safety Information	D-1
Caution Notices	D-4
Index	X-1

About This Guide

This guide explains how to set up the IBM 2216, perform initial configuration and correct some problems that might occur during installation.

Who Should Use This Guide

This guide is intended to be used by the person responsible for installing the 2216. This person should be familiar with installation and cabling charts.

About the Software

The software that supports the IBM 2216 is IBM Nways Multiprotocol Access Services (Version 3 is licensed program number 5765-D47). The software has these components:

- The base code, which is installed at the factory on the 2216, consists of:
 - The code that provides the routing, bridging, data link switching, and SNMP agent functions for the device.
 - The router user interface, which allows you to configure, monitor, and use the IBM Nways Multiprotocol Access Services base code that is installed on the device. The router user interface is accessed locally through an ASCII terminal or emulator attached to the service port, or remotely through a Telnet session or modem-attached device.
- The Configuration Program for IBM Nways Multiprotocol Access Services (*Configuration Program*), a graphical user interface that allows you to configure the device from a stand-alone workstation. The configuration program includes error checking and online help information.

The configuration program is not preloaded at the factory; it is shipped separately from the device as part of the software order. (See the *Configuration Program User Guide*, GC30-3830, for the server address and directories to FTP a copy of the configuration program.)

How to Proceed

Note: If you are upgrading from Version 1 Release 1 of the Multiprotocol Access Services (the operating system software) to Version 2 Release 1 (or higher), see the upgrading/migrating information in the *Service and Maintenance Manual*.

Installation and Initial Configuration

1. Install the IBM 2216 using the *Installation and Initial Configuration Guide* provided with the product. (Alternatively, installation by IBM service personnel is available. Contact your IBM representative for additional information.)

Note: Installation of the cables for the FC 2299 (Parallel Channel Adapter) requires IBM service or channel trained personnel.

2. Connect a terminal to the serial port or PCMCIA modem to enable yourself to do the initial configuration steps. (See “Access Methods” on page 3-1.)
3. Access the IBM 2216 firmware to do initial configuration. (See “The Firmware Interface” on page B-1.)
4. Create network interfaces for each port of each adapter that is installed in the 2216 using the **Add Device** command. (See “Adding an Adapter at Initial Configuration” on page B-4 for information on using the “Add Device” command.
5. Run the “Quick Configuration” program to perform the initial configuration and activate your IBM 2216. (See step 2 on page 4-1.)

Configuration

1. Perform final configuration. See the *Configuration Program User's Guide* and *Software User's Guide*.

2216 Library Overview

The following shows the publications in the IBM 2216 library, arranged according to tasks.

Planning and Installation

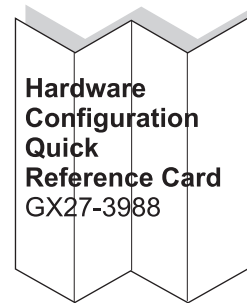

Configuration

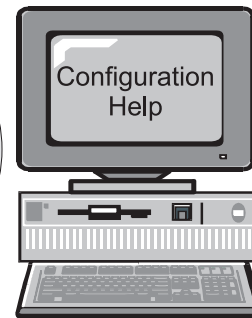
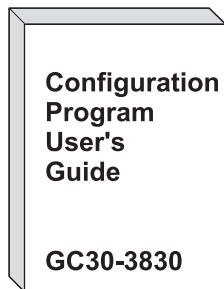

Diagnostics/Maintenance

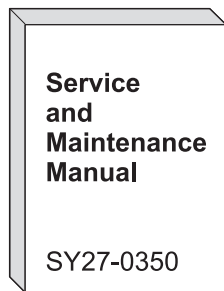

Operations and Network Administration

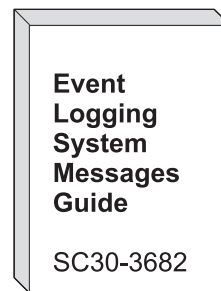
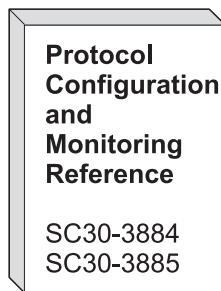
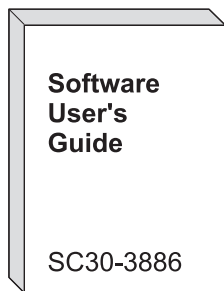

Common Tasks and the IBM 2216 Library

Table 0-1. Hardcopy Publications that Are Shipped with the 2216

These documents are shipped in hardcopy and are also contained on the 2216 CD-ROM, SK2T-0405.

Planning

GA27-4105 *2216 Nways Multiaccess Connector Introduction and Planning Guide*

This book explains how to prepare for installation and select the hardware that you want to purchase. It includes specifications for the hardware and software for your network. It also provides information on the management of routing networks.

Installation

GA27-4106 *2216 Nways Multiaccess Connector Installation and Initial Configuration Guide*

This booklet explains how to install the IBM 2216 and verify its installation.

GX27-3988 *2216 Nways Multiaccess Connector Hardware Configuration Quick Reference*

This reference card is used for entering and saving hardware configuration information used to determine the correct state of an IBM 2216.

Diagnostics and Maintenance

SY27-0350 *2216 Nways Multiaccess Connector Service and Maintenance Manual*

This book provides instructions for diagnosing problems with and repairing the IBM 2216.

Safety

SD21-0030 *Caution: Safety Information—Read This First*

This book provides translations of caution and danger notices applicable to the installation and maintenance of a IBM 2216.

Table 0-2. Softcopy Publications that Are Shipped on the CD-ROM

Operations and Network Management

The following list shows the books that support the Nways Multiprotocol Access Services program.

SC30-3886 *Nways Multiprotocol Access Services Software User's Guide*

This book explains how to:

- Configure, monitor, and use the Nways Multiprotocol Access Services software.
- Use the Nways Multiprotocol Access Services command-line router user interface to configure and monitor the network interfaces and link-layer protocols shipped with the IBM 2216.

SC30-3884 *Nways Multiprotocol Access Services Protocol Configuration and Monitoring Reference, Volume 1*

SC30-3885 *Nways Multiprotocol Access Services Protocol Configuration and Monitoring Reference, Volume 2*

These books describe how to access and use the Nways Multiprotocol Access Services command-line user interface to configure and monitor the routing protocol software shipped with the product.

They include information about each of the protocols that the device supports.

SC30-3682 *Nways Event Logging System Messages Guide*

This book contains a listing of the error codes that can occur, along with descriptions and recommended actions to correct the errors.

Configuration

GC30-3830 *Configuration Program User's Guide*

This book discusses how to use the Nways Multiprotocol Access Services Configuration Program.

Visit our Web Sites

This IBM web page provides product information:

<http://www.networking.ibm.com/216/216prod.html>

Information, Updates, and Corrections

This page provides information on engineering changes, clarifications, and fixes that were implemented after the books were printed:

<http://www.networking.ibm.com/216/216lib.html#relnts>

Product Support

This page provides downloads and additional support information:

<http://www.networking.ibm.com/support/2216>

Chapter 1. Installing the 2216

Before You Begin: The illustrations in this guide represent one possible configuration for the IBM 2216. The illustrations assume that the redundant power supply is installed and almost all of the slots are filled.

These instructions explain how to rack-mount and surface-mount the IBM 2216. You will need a second person to help lift the IBM 2216 while it is being mounted.

CAUTION:

A fully populated IBM 2216 weighs about 43.1 kg (95 lb).

1. Unpack and Verify

Unpack the IBM 2216 and verify that, along with this guide, the following items were included:

Documentation

- *Caution: Safety Information—Read This First*, SD21-0030
- *IBM 2216 Introduction and Planning Guide*, GA27-4105
- *IBM 2216 Service and Maintenance Manual*, SY27-0350
- *IBM 2216 Hardware Configuration Quick Reference Card*, GX27-3988
- *Configuration Program User's Guide*, GC30-3830

Hardware

- Any cables ordered
- Rack-Mount Installation Aid
- Power cord for each power supply
- PCMCIA Modem (except in countries where the PCMCIA modem is not available)

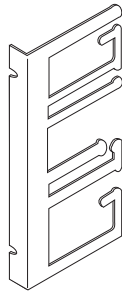

- Surface-mounting cable bracket:
- Rack-mounting cable bracket if the IBM 2216 contains FC 2299

For:

Surfacing-mounting - continue with step 2a on page 1-2.

Rack-mounting- go to with step 2b on page 1-3.

2a. Surface-Mounting the 2216

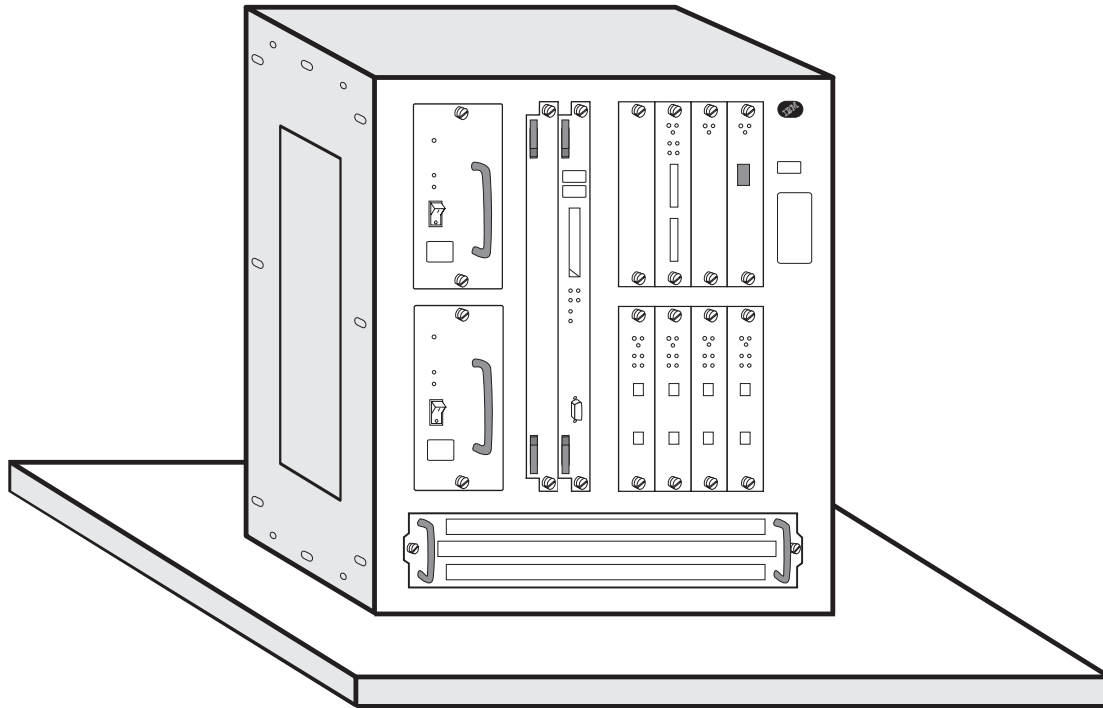

You need the following items:

- Cables, as required
- Cable bracket

If you will use the surface-mount cable bracket, **go to step 4 on page 1-5.**

If you will not use the surface-mount cable bracket, **go to step 9 on page 1-9.**

2b. Rack-Mounting the 2216

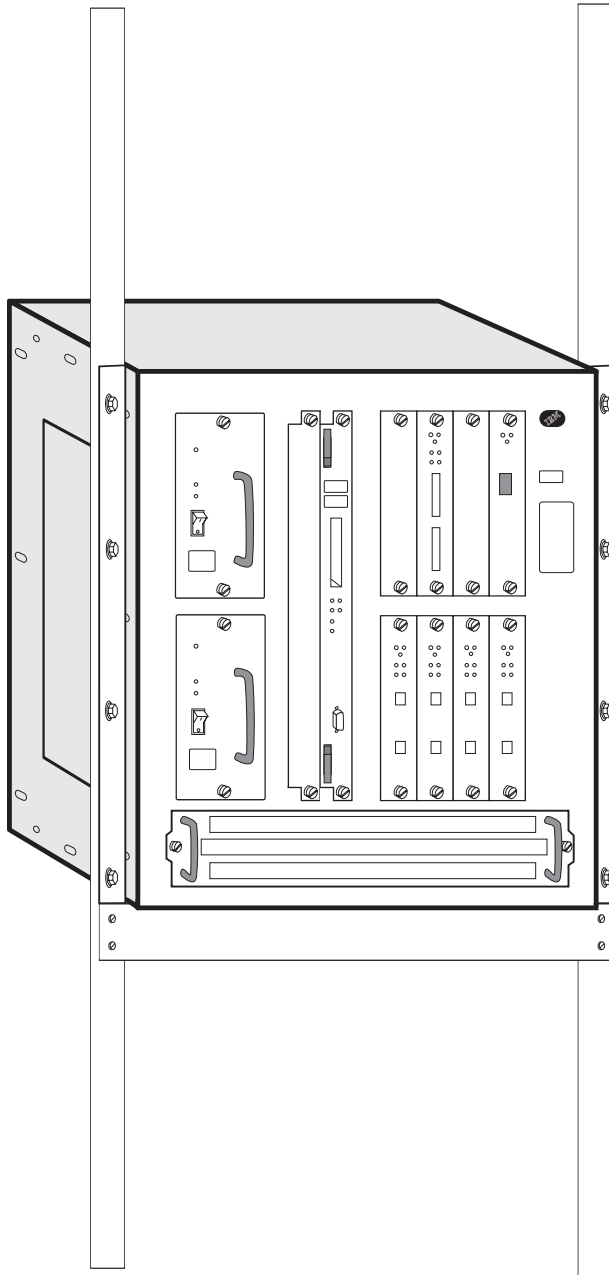

You need the following items:

- Cables, as required
- Ten rack-mounting screws
- Screwdriver

Notes:

1. Have a second person help hold the IBM 2216 while it is being mounted.
2. If you have a shelf for the rack, install it before continuing.
3. Do not use the installation aid if you have a shelf installed.

Continue with step 3 on page 1-4.

3. Rack-Mounting

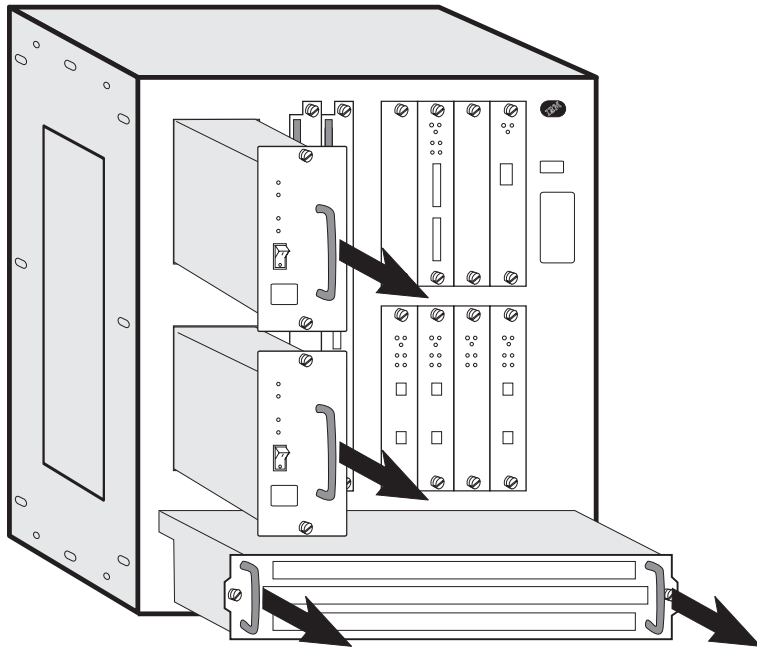

To make the IBM 2216 easier to lift, remove:

1. The fan tray
2. Each power supply.

To remove them, loosen the screws on each component and pull the handles.

4. Rack-Mounting (Optional for Surface-Mounting)

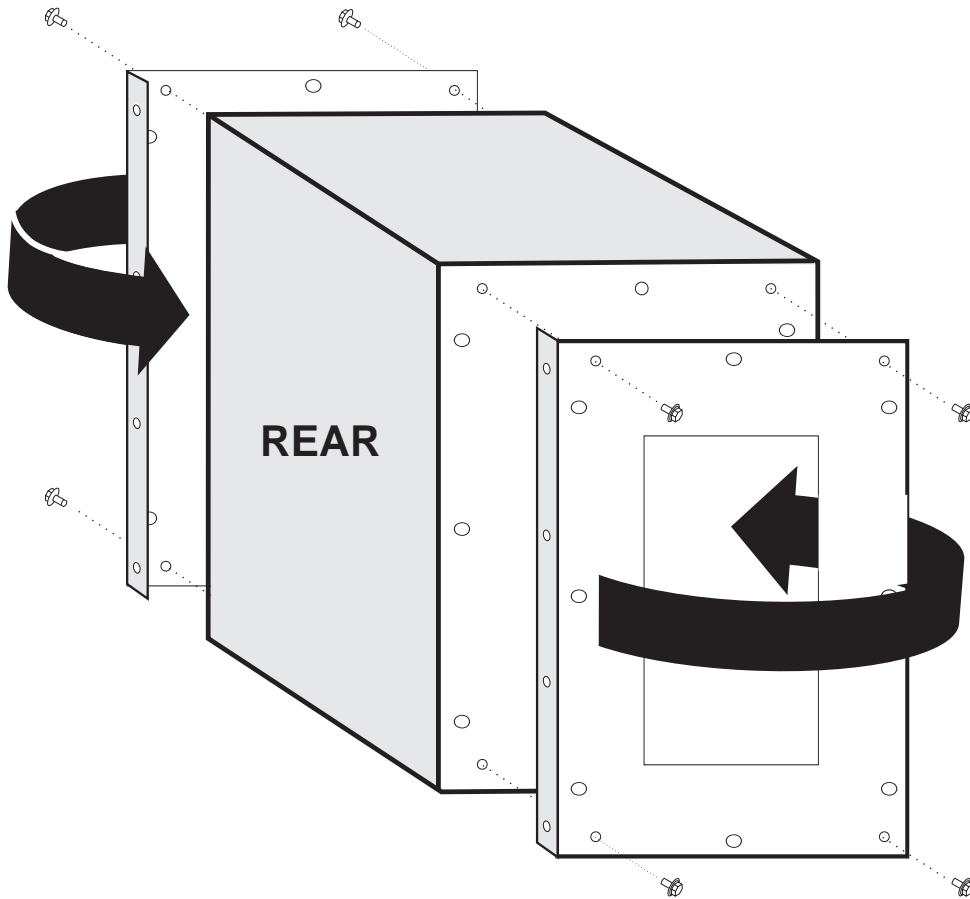

The IBM 2216 mounting brackets are shipped with the flanges facing the rear:

1. Remove the two screws at the top and bottom of each bracket
2. Reverse each bracket so that the IBM 2216 can be rack-mounted
3. Reinstall the four screws.

When the brackets are fitted correctly, the letter embossed on each bracket is in the top-rear corner; an A on the right side and a B on the left side.

5a. Surface-Mounting

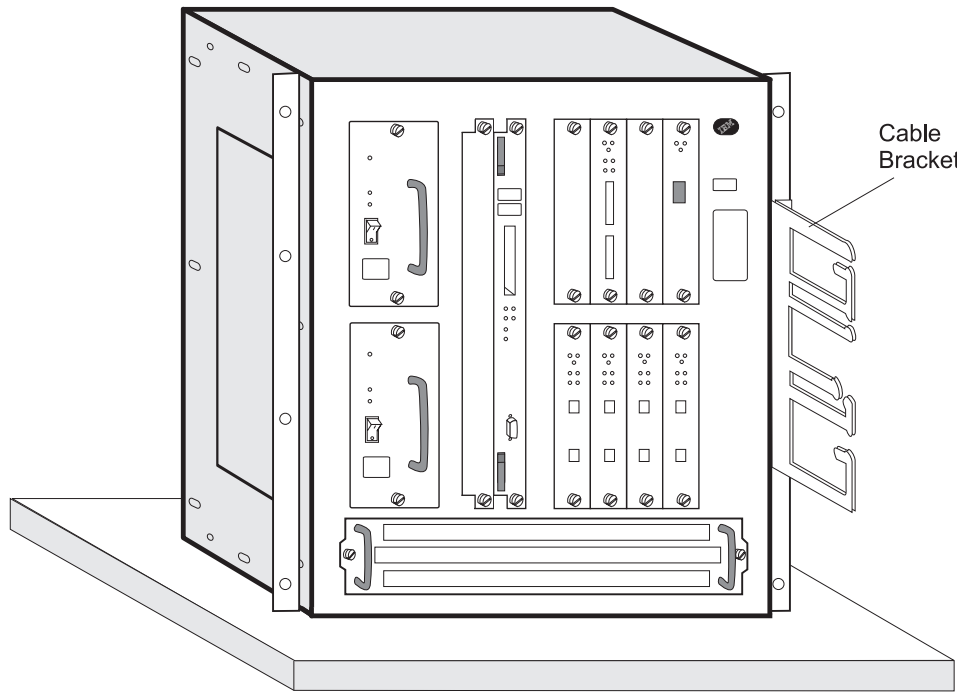

Attach the surface-mount cable bracket to the IBM 2216 mounting bracket with the screws, nuts, and washers that were supplied with the IBM 2216.

5b. Rack-Mounting

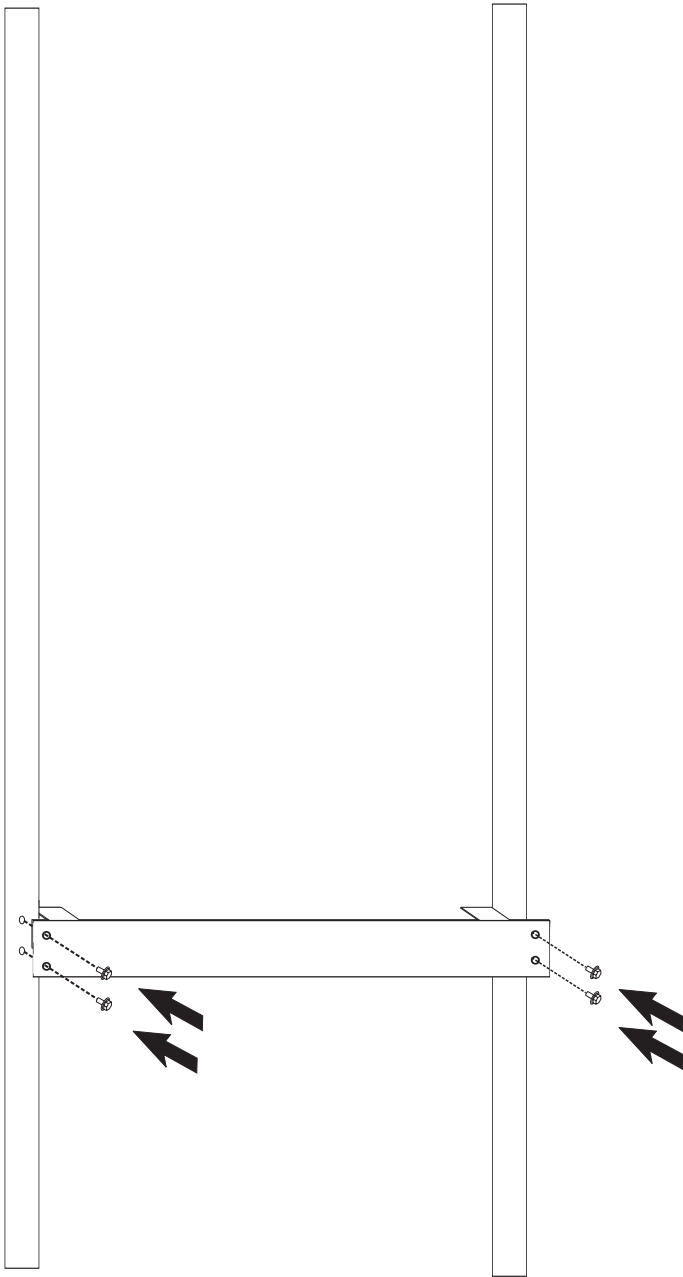

The installation aid is a metal bar that supports the IBM 2216 as you install it in the rack. The installation aid ensures that the IBM 2216 and rack are lined up correctly.

Line up the holes in the installation aid with the rack and install all screws.

6. Rack-Mounting

With the second person's help, set the IBM 2216 on the IBM 2216 installation aid or on the shelf. The mounting brackets keep the IBM 2216 from falling into the rack during installation.

With the installation aid installed, one person can steady the IBM 2216 while you complete the next step.

7. Rack-Mounting

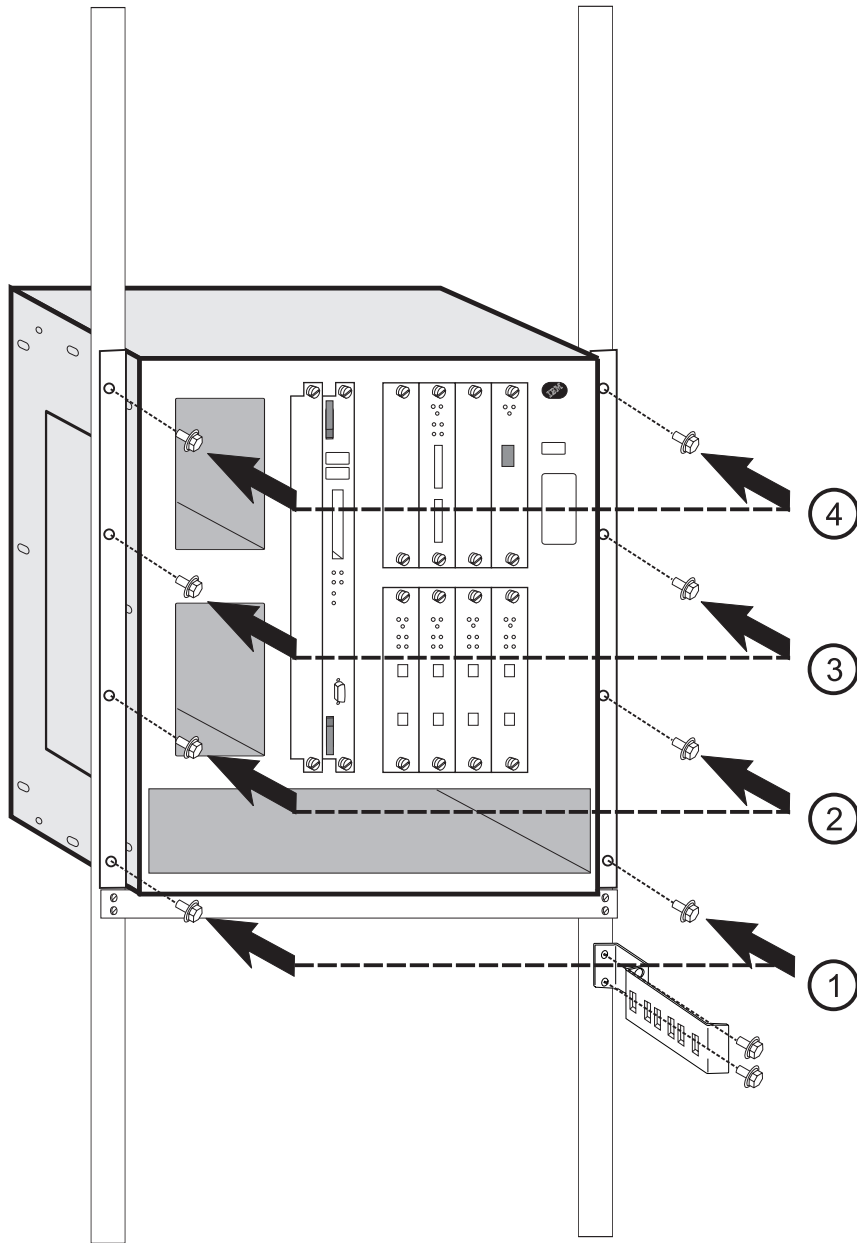

1. Install the pairs of screws in the order shown.
2. For FC 2299: Using 2 screws, install the rack-mounting cable bracket onto the front of the rack below the IBM 2216.

8. Rack-Mounting

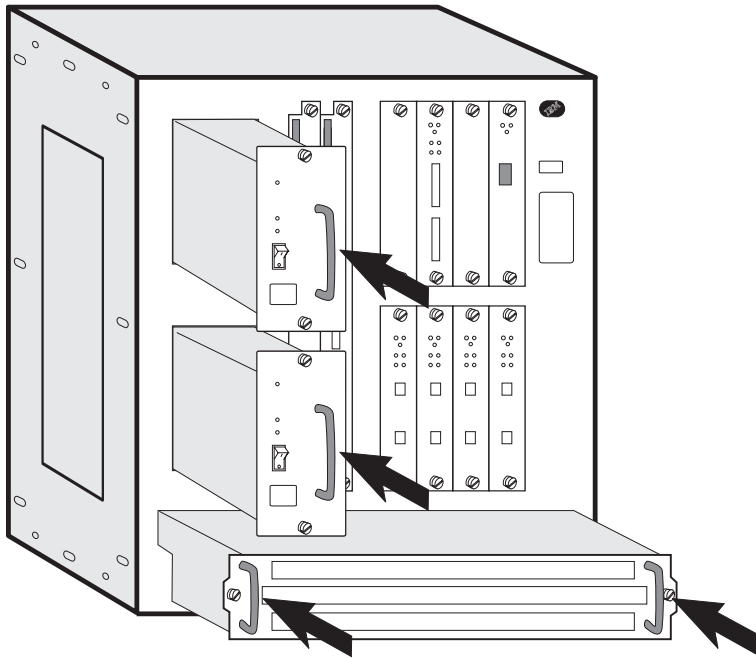

Reinstall the fan tray and each power supply, making sure the screws are secured.

If the power supply resists, shift it to the left. If the fan tray resists, gently rock it.

9. Rack- or Surface-Mounting

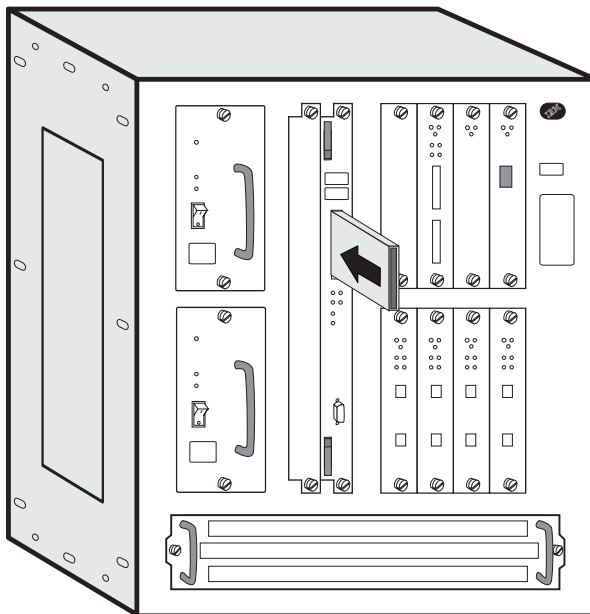

If you are installing a PCMCIA modem, slide it into either of the PCMCIA slots on the system card. Attach the telephone cable to the modem (a triangle identifies the top of the cable).

10. Rack- or Surface-Mounting

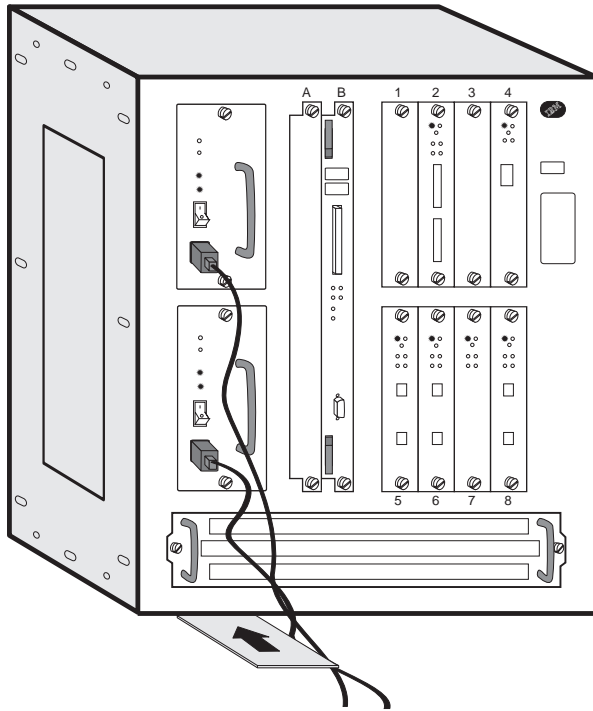

1. Verify that **all** thumbscrews are tight (even if you did not loosen them during installation).
2. Connect the power cords to the IBM 2216 and the power outlets. Switch on each power supply. After 5 minutes, verify that the correct LEDs are on. (See "System Card Status" on page 2-3.)
3. Ensure that the *Hardware Configuration Quick Reference* card is completed and placed in the area provided under the IBM 2216 on the left.

11. Complete the Setup (Rack- or Surface-Mounting)

1. Connect the cables (except for the Parallel Channel Adapter, FC 2299).
Note: If you have FC 2299 (Parallel Channel Adapter), the installation of the cables requires a Channel trained IBM CE or customer's Channel trained person.
Call IBM Service to install the cables for FC 2299. The Parallel Channel and its attached devices will be disrupted if the cables are not installed properly.
2. Label the IBM 2216 with its unique unit number or name on the top right of the front panel.
3. Report the phone number of the modem to the network administrator and return all the charts. The IBM 2216 is ready to be configured.

12. IBM CE Tasks for FC 2299

1. Connect the adapter cables to FC 2299 (using the procedures in the *Service and Maintenance Manual* in the "Installing Channel Adapters" section). Do not connect to the host channel cables yet.
2. Run wrap tests to verify that all adapter cables are OK.
3. Connect the host channel cables to the adapter cables.

Chapter 2. Problem Solving

To identify and correct any problems that occur during setup, answer the questions and take the appropriate actions, as indicated:

On the power supply, is the AC OK LED off?

Yes: There is no AC source voltage.

1. Switch each power supply off.
2. Check the power source.
3. Ensure that the power cord is attached correctly.
4. Switch each power supply on.

If the problem is not corrected, contact your service representative.

No: Go to the next question.

On the power supply, is the DC OK LED off?

Yes: There is no +5 V, +12 V, or -48 V dc output voltage.

1. Switch each power supply off.
2. Reseat the power supply, ensuring that the power cord is attached correctly, and switch each power supply on.

If the problem is not corrected, contact your service representative.

No: Go to the next question.

On the power supply, is the Overcurrent LED on?

Yes: There is an overcurrent condition in an adapter or in the fan tray.

1. Remove the adapter that has its top yellow LED on. If none is on, remove the fan tray.
2. Press the Overcurrent Reset button.

If the problem is not corrected, contact your service representative.

No: Go to the next question.

On the system card, is the OK yellow LED on?

Yes: There is a fault in the card.

1. Switch off each power supply.
2. Reseat the card.
3. Switch on each power supply.

If the problem is not corrected, contact your service representative.

No: Go to the next question.

On the system card, is the OK green LED off?

Yes: The green LED is switched on by the operational code.

If the green LED fails to come on, contact your service representative.

No: Go to the next question.

On the system card, is the PCMCIA port LED on?

Yes: Either the PCMCIA card slot is empty or the card failed the power-on self-test. Reseat the card.

If the problem is not corrected, contact your service representative.

No: Go to the next question.

On any card (slots 1 through 8), is the top yellow LED on?

Yes: There is a fault in the card. Reseat the adapter.

If the problem is not corrected, contact your service representative.

No: Go to the next question.

On any card (slots 1 through 8), is the wrong slot LED on?

Yes: The adapter is in the wrong slot.

1. Find the correct slot.
 - If adapter LIC 280 or LIC 281 is in slot 3, then slot 4 must be empty.
 - If adapter LIC 280 or LIC 281 is in slot 4, then slot 3 must be empty.
 - If adapter LIC 280 or LIC 281 is in slot 7, then slot 8 must be empty.
 - If adapter LIC 280 or LIC 281 is in slot 8, then slot 7 must be empty.

See the "Slots and Adapters" on page A-1 for a list of restrictions regarding adapters and IBM 2216 slots.

2. Move the adapter to the correct slot.

If the problem is not corrected, contact your service representative.

No: If you did not answer yes to any question, contact your service representative.

LED Indicators

The IBM 2216 has a number of light-emitting diodes (LEDs) that indicate how the unit is functioning.

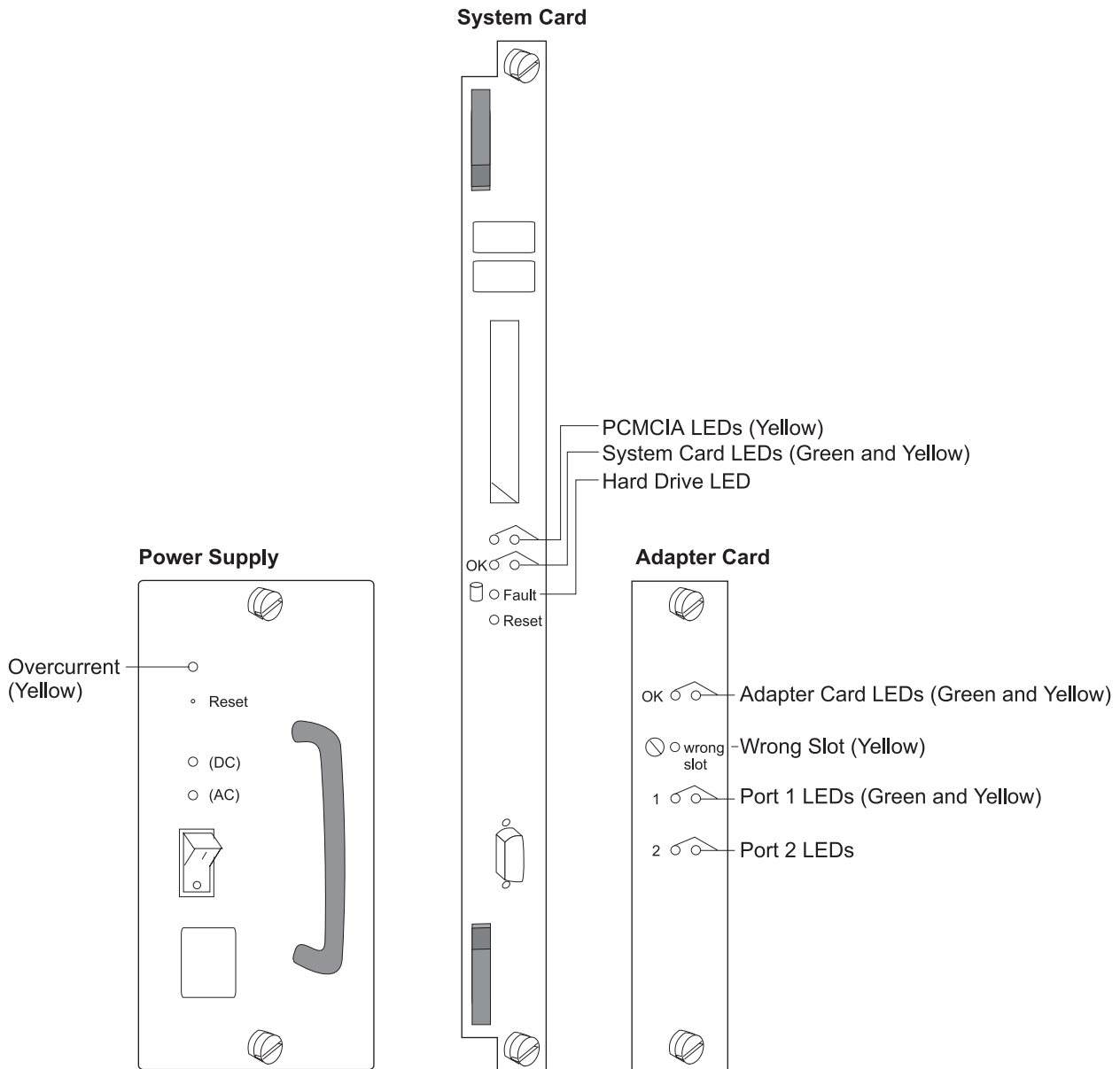

Figure 2-1. Power Supply, System Card, and Adapter Card LEDs

Power Supply Status

LEDs	Meaning
Yellow (Overcurrent)	On - There is an overcurrent condition with the -48 V to one or more of the adapters (slots 1–8) or the +12 V to the fan tray.
Green DC	On - +5 V, +12 V, and -48 V are OK.
Green AC	On - AC source voltage is present and within tolerance.

System Card Status

LEDs	Meaning
PCMCIA 1 or PCMCIA 2 (Yellow)	On - PCMCIA device has a fault, is not installed, or is not seated correctly. Off - Device passed self-tests
OK (Green)	On - Card hardware is operating normally. Blinking - Loading from hard file
(Yellow)	On - Card hardware has a fault.
Fault Hard Drive (Yellow)	On - Hard drive has failed.

Adapter Card Status

LEDs	Meaning
OK (Green)	On - Adapter is operational.
(Yellow)	On - Adapter has a fault.
Wrong slot (Yellow)	On - Adapter is in the wrong slot. The wrong slot LED is ON only when an adapter that is plugged into the 2216 violates the plugging rules described in Appendix A, "Adapter Plugging Defaults" on page A-1.
Green port ¹	On - Port is operating normally (enabled and configured). Off - Port is not configured or is disabled. Blinking (for ESCON adapter only) - The optical power measurement test is running.
Yellow port ¹	On - One or more ports has a hardware fault. Blinking - One or more ports has a port I/O or network failure. Use the Maintenance Analysis Procedures (MAPs) to isolate. Off - No problem detected.

¹ The port LEDs of the multiport WAN adapters (FC 2282, FC 2290, and FC 2291) reflect the status of one or more of the ports.

Important Phone Numbers

Contact Name	Telephone Number
System Administrator:	
Service Representative:	

Chapter 3. Accessing the 2216

This chapter explains how to access and manage the IBM 2216's operational and configuration software.

The network administrator or the IBM Support Center can access the IBM 2216 locally or remotely for configuration or diagnostics. The following sections describe accessing the IBM 2216, configuration tools, and monitoring tools.

Access Methods

The IBM 2216 must be configured as part of the installation process. It needs either an IP address or configuration for LAN emulation. Therefore, you have to access it in one of the following ways:

- Through the PCMCIA modem or through a modem attached to the EIA 232 service port. These are the forms of remote connection, which rely on the telephone lines.
- Through a null modem cable attached to the EIA 232 service port. This is known as local connection.

You can set up both a local and a remote connection to the IBM 2216. However, only one port can be active at any given time. If a workstation is connected locally to the serial port and a call comes in over the PCMCIA modem, priority is given to the call. After the call, the workstation being used to configure will have to log back into the IBM 2216.

With local or remote connection, you can use a teletypewriter (TTY) connection. TTY requires communications software. The preferred method is to use Serial Line Internet Protocol (SLIP) over the local or remote connection. If you use SLIP, you must have Transmission Control Protocol/Internet Protocol (TCP/IP) running on your workstation.

Alternatively, you can use the Xmodem protocol and ProComm or other communication software for file transfers.

Figures 3-1 and 3-2 illustrate a remote connection using the PCMCIA modem and a local connection using a null modem.

Note: Post-installation configuration changes can be done using the Configuration Program.

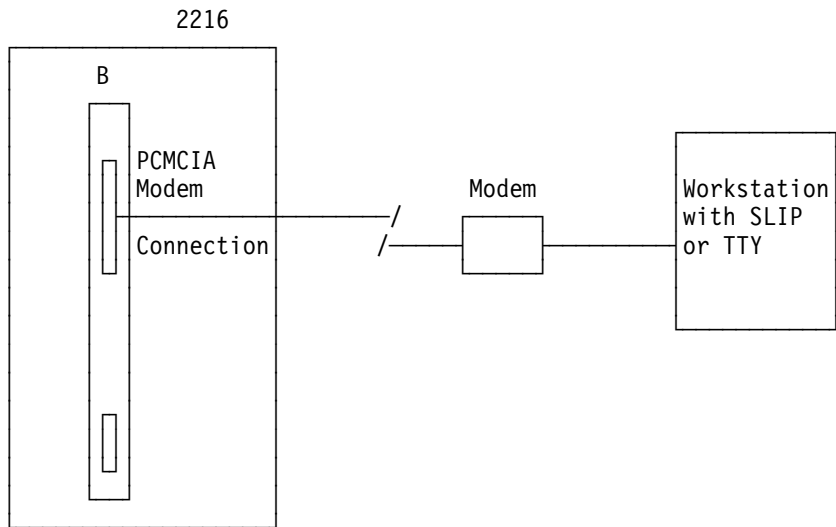

Figure 3-1. Remote Serial Connection to the PCMCIA Modem

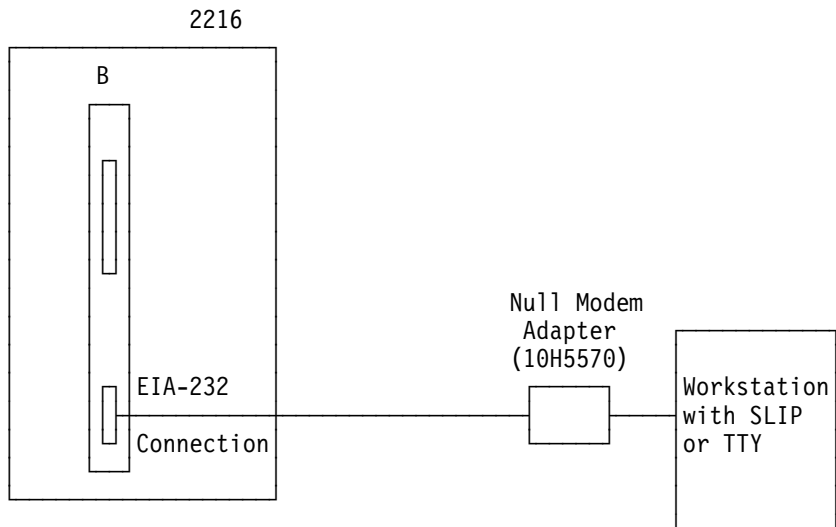

Figure 3-2. Local Serial Connection to the EIA 232 Port

SLIP Addresses

The default SLIP IP addresses are:

For the workstation:

10.1.1.3

For the IBM 2216:

10.1.1.2

For instructions about installing SLIP, refer to the documentation for your version of TCP/IP.

Serial Port and PCMCIA Modem Default Settings

These are the default settings for the serial port:

Speed 19.2 Kbps
Parity None
Data Bits 8
Stop Bits 1

The PCMCIA modem is a standard item that is shipped with the IBM 2216. The modem is a 33.6-Kbps V.34 data modem. It is set up with a default speed of auto-detect. The parity, data bits, and stop bits are the same as those of the serial port: None, 8, and 1.

Attaching an ASCII Terminal

Attach an ASCII terminal or emulator (with the appropriate emulation software) to provide local or remote access to the 2216 as shown in Figure 3-1 on page 3-2 and Figure 3-2 on page 3-2.

The DEC VT100 ASCII terminal is supported, as well as devices such as personal computer systems that are configured to emulate it. Configure a VT100 with:

- No parity
- 8-bit word length
- 1 stop bit
- 300 bps–38.4 Kbps bit rate

Note: The speed must match the speed of the connected terminal. It is 19.2 Kbps if the serial service port is used, any speed if the PCMCIA modem is used and is set to autobaud.

ASCII Terminal Setup Attributes

This is a list of all the options required to set up a terminal for use with the IBM 2216 that is connected to the service port. Not every terminal (particularly 3151 and 3161) will have all these options. You should use the information to set the options that you can set on your terminal.

Terminal Settings and Function Keys

Terminal Settings

Baud Rate: 19200 bits per second
Parity: None
Stop bits: 1

Duplex: Full Duplex
Flow Control: XON/XOFF and RTS/CTS (see note 1)

Screen Control: ANSI Full screen
Screen Width: 80 Characters
Screen Height: 24 Lines
Line Wrap: ON
Screen Scroll: ON

Carriage Return Translation: CR (0Dx)
Backspace Translation: Destructive

Notes:

1. Terminals and Terminal emulator programs which do not have flow control options should be set to "Permanent Request to Send."
2. Terminal emulators that require a terminal type selection should be set to VT-220.

Function Keys

Function 1 (F1):	<Esc> O P	Hex: 1B 4F 50
Function 2 (F2):	<Esc> O Q	Hex: 1B 4F 51
Function 3 (F3):	<Esc> O R	Hex: 1B 4F 52
Function 4 (F4):	<Esc> O S	Hex: 1B 4F 53
Function 6 (F6):	<Esc> [0 0 6 q	Hex: 1B 5B 30 30 36 71
Function 9 (F9):	<Esc> [0 0 9 q	Hex: 1B 5B 30 30 39 71

Note:

In the definitions of function keys 1 through 4, the character following the <ESC> is the *capital* letter O.

In the definition of keys 6 and 9 the characters following the <ESC> and the [are number 0 (zero).

In all six definitions, the characters are case sensitive.

Managing the Operational and Configuration Software

The IBM 2216 comes from the factory with its operational software loaded. However, if the operational software needs an upgrade or replacement, you have to reload it. Binary configuration files can be created using the Configuration Program. These files can be uploaded to the IBM 2216 to reconfigure it.

IBM 2216 Software and Configuration Change Management

The IBM 2216 is capable of storing two copies of its operational software and four copies of configuration information for each copy of the operational software. Without interrupting the operation of the IBM 2216, you can store software or configuration files in it. Changes to the configuration are activated in one of the following ways: immediately, after a timed interval, or at the next restart.

Should the IBM 2216 fail when a new version of the operational software is activated, one of the backup versions can be restored.

You use the command line interface for change management operations and TFTP or Xmodem to transfer files.

Chapter 4. Performing the Initial Configuration

If you have a new router with no configuration, or if you have cleared the router's configuration or encountered a problem that cleared the configuration, you must perform the steps in this section before you can send an existing configuration to the router.

Setting Up the Router (Initial Configuration)

To perform initial configuration on the router, you must first establish access to the router. You can establish access either locally or remotely as described in "Access Methods" on page 3-1. Then:

1. At the `Config Only>` prompt, use the **add device** command to configure the primary LAN interface.
2. At the `Config only>` prompt, type **qconfig** and press **Enter** to start the "Quick Configuration" program
3. Perform an initial configuration to establish the IP address and IP mask for the primary LAN interface for the router as follows:
 - a. **Configure Bridging**
 - 1) Enter **No** to Configure Bridging?
 - b. **Configure Protocols**
 - 1) Enter **Yes** to Configure Protocols?
 - c. **Configuring IP**
 - 1) Enter **Yes** to Configure IP?
 - 2) For the LAN interface that will communicate with the configuration program, enter **Yes** to Configure IP on this interface?
 - 3) Enter the IP address at the IP Address prompt
 - 4) Enter the IP mask at the Address Mask prompt
 - 5) If you have other interfaces, enter **No** to Configure IP on this interface?
 - 6) Enter **No** to Enable Dynamic Routing?
 - 7) Enter **Yes** to Define Community with Read_Write_Trap Access?
Enter the community name that will have Read_Write_Trap access
 - 8) Enter **Yes** to Save this configuration?
 - d. **Configuring IPX and DECnet**
 - 1) Enter **No** to Configure IPX?
 - 2) Enter **No** to Configure DNA?
 - e. **Saving the Configuration file**
 - 1) Enter **Yes** to Do you want to write this configuration?
4. Press the **Ctrl-p** keys to exit `Config>`
5. Enter **reload** to restart the router

When the router completes the restart sequence, it can communicate with the configuration program.

After Initial Configuration

Important: After the 2216 is configured and operational, *always* back up the active configuration file. Keeping this file enables you to re-establish the 2216 on the network if the active configuration becomes corrupted.

You can back up the active configuration file by retrieving it and storing it in the workstation.

Full Configuration

The initial configuration procedure you have just performed will enable you to access the IBM 2216 over the network if you configured an IP address for it.

The configuration provided by QCONFIG depends upon many default values for parameters, some of which may not be appropriate to your installation. You may need to modify the configuration that you have created using QCONFIG to customize the IBM 2216 to work on your network. You can do this using either of these methods:

- Configuration Program

The Configuration Program is the *recommended* configuration method for these reasons:

1. It can enable you to keep a number of copies of configuration files on a server for uploading to the appropriate IBM 2216s.
2. It does not alter any configuration parameters dynamically. This feature helps you control changes to the IBM 2216 configurations.
3. It performs more input validation and cross-checking of the configuration parameters than the other methods.

- Command line interface (OPCON)

The command line interface causes certain parameters to be altered dynamically. The binary files that are created are saved on the hard disk of the IBM 2216, not in the workstation. This characteristic makes it more difficult to manage the configuration of the IBM 2216 than if the configuration program were used to create the configuration files. However, the command line interface can be used to monitor the operations of the IBM 2216, whereas the Configuration Program cannot.

The command line interface is also useful when you want to change one of the parameters that can be dynamically altered. For more information about the command line interface, refer to the *Software User's Guide*.

Use the *Configuration Program User's Guide* in order to create a complete configuration that is suitable for your network.

Appendix A. Adapter Plugging Defaults

Units assembled at the factory follow the plugging rules that are described in this appendix.

Plugging Sequences

Table A-1 illustrates how the slots are numbered: two rows of four slots, numbered 1 through 8.

Slot 1	Slot 2	Slot 3	Slot 4
Slot 5	Slot 6	Slot 7	Slot 8

Table A-2 and Table A-3 show the default sequence of installation for the various adapters.

- FC 2280 and FC 2281 are installed left to right, beginning with slot 1. A maximum of six can be installed in any single IBM 2216.

first	third	fifth	
second	fourth	sixth	

- Other adapters are installed right-to-left in the first-available slot beginning with slot 8 on the bottom and far right.

eighth	sixth	fourth	third
seventh	fifth	second	first

Slots and Adapters

There are two large slots, designated *A* and *B*, on the IBM 2216. Slot *A* is unused. Slot *B* is occupied by the system card. In addition, there are eight adapter slots, designated 1 through 8.

- 2280 or 2281 — If **six** Token-Ring (FC 2280) and Ethernet (FC 2281) adapters are installed in any combination, no other adapters can be installed.
- 2280 or 2281 — If a combination of **five** 2280 and 2281 adapters is to be installed, then two other adapters can also be installed.
- The IBM 2216 supports a maximum of:
 - **Four** channel adapters, which can be Parallel Channel Adapters (FC 2299) in any combination with ESCON adapters (FC 2287)
 - **Two** ATM adapters (FC 2284, 2293, 2294, or 2295)**Note:** This adapter is also used for fast token-ring (FasTR)

- **One** 4-port ISDN PRI/Channelized (T1/J1 interface) adapter (FC 2297)
One 4-port ISDN PRI/Channelized T1 Daughter card (FC 2251) can be added to the base 4-port ISDN PRI/Channelized T1/J1 adapter (which produces a total of 8 ports on a single adapter).
- **One** 4-port ISDN PRI/Channelized (E1 interface) adapter (FC 2298)
One 4-port ISDN PRI/Channelized E1 Daughter card (FC 2252) can be added to the base 4-port ISDN PRI/Channelized E1 adapter (which produces a total of 8 ports on a single adapter).
- **Four** ISDN adapters (FC 2283 or FC 2292)

A maximum of 8 ISDN interfaces are allowed. Four can be FC 2283 or 2292.

Note: You can configure a 2216 with as many high-speed adapters (FDDI FC 2286, 10/100-Mbps Ethernet FC 2288, and HSSI FC 2289) as desired; however, you may not be able to achieve full media throughput concurrently on all the adapters. When planning for installation, review system performance expectations with an IBM representative.

Adapters can be installed in any of the eight adapter slots with the following restrictions:

1. If the 2-port Token-Ring (FC 2280) or 2-port Ethernet (FC 2281) adapter is plugged into slot 3 and active, then slot 4 cannot be used.
2. If the 2-port Token-Ring (FC 2280) or 2-port Ethernet (FC 2281) is plugged into slot 4 and active, then slot 3 cannot be used.
3. If the 2-port Token-Ring (FC 2280) or 2-port Ethernet (FC 2281) adapter is plugged into slot 7 and active, then slot 8 cannot be used.
4. If the 2-port Token-Ring (FC 2280) or 2-port Ethernet (FC 2281) adapter is plugged into slot 8 and active, then slot 7 cannot be used.

Appendix B. Common Tasks

This appendix provides a series of questions and answers dealing with common IBM 2216 installation, operation, and maintenance tasks, with suggestions as to where to find further help in performing them.

LED States / Adapter Status

Question How do I check the state of the adapters in my IBM 2216?

Answer The LED state on the front of the adapters indicate the status of the adapter. (See "Adapter Card Status" on page 2-3.) Also, the *Maintenance Guide* treats problem determination in more detail.

The Firmware Interface

Question What is the firmware interface? How do I access it?

Answer The firmware is the microcode lying underneath the operational code running on the 2216. It is used primarily by service personnel in problem determination. The firmware is accessed by booting the IBM 2216 and stopping the boot process with the **F1** key. It displays a menu with a number of options. Briefly, you should have a VT220 terminal with the following settings: 19.2 Kbps, 8-N-1. You can use a null-modem cable for local access or a modem attachment for remote access.

See Chapter 3, "Accessing the 2216" on page 3-1 for more information.

Command Line Interface

Question How do I access the command line interface (the operating code) from within the firmware?

Answer From within the **firmware menu system** (System Management Services), press **F9**. The * prompt is displayed after the system boots.

The command line interface is described in the *Multiprotocol Access Services Software User's Guide*.

Navigating Through the Command Line Interface

Question How do I use the commands in the Command Line Interface?

Answer The structure of the interface is shown in Figure B-1 on page B-2.

The *Multiprotocol Access Services Software User's Guide* describes the entire command line interface. The basic prompts that you use are the:

- * prompt, which is the OPerating CONsole (OPCON) prompt, the initial entry point to the command line interface
- Config> prompt, which is used for configuration changes
- + prompt, which is known as monitoring or GWCON.

The basic commands are:

- Type **?** and press **Enter** at any time to view a list of possible commands.
- Type **exit** and press **Enter** to return to the + prompt and to the Config> prompt.
- Press the **Ctrl-p** keys to return to the * prompt.

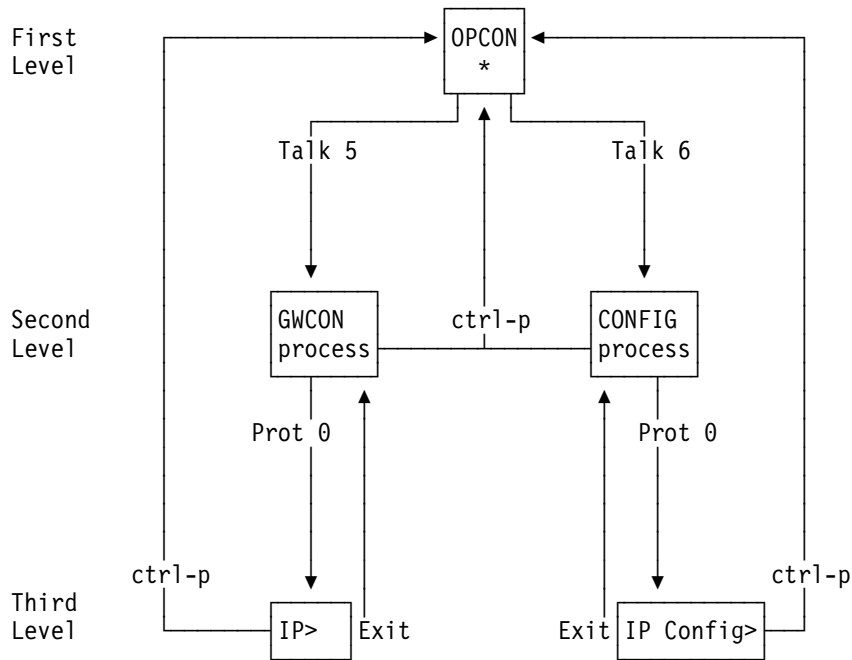

Figure B-1. Structure of the Command Line Interface (with the protocol command as an example)

Displaying List of Configured Interfaces

Question How do I display a list of active interfaces?

Answer

1. Access the command line interface (the * prompt).
2. Type **talk 6** and press **Enter** twice to reach the Config> prompt.
3. Enter **list dev**.
4. Press **Ctrl-p** to return to the OPCON (*) prompt.

Displaying the Operational State of the Interfaces

Question How do I display the state (up, down, disabled, etc.) of an interface?

Answer

1. Access the command line interface (the * prompt).
2. Type **talk 5** and press **Enter** twice to reach the + (monitoring) prompt.
3. Enter **configuration**.
4. Press **Ctrl-p** to return to the OPCON (*) prompt.

Verifying Connectivity

Question How do I verify that a given IP address is online?

Answer

1. Access the command line interface (the * prompt).
2. Type **talk 5** and press **Enter** twice to reach the + prompt.
3. Type **protocol** and press **Enter**.
4. Type **ip** and press **Enter**. The prompt changes to IP>.
5. Type **ping IP address value** and press **Enter**. Press **Enter** to stop the ping process.
6. Type **exit** at the IP> prompt and press **Enter**. The prompt changes to +.
7. Press **Ctrl-p** to return to the OPCON (*) prompt.

Viewing Vital Software Data

Question How do I view vital software data?

Answer

1. At the * prompt, type **talk 6** and press **Enter** twice. The Config> prompt appears.
2. Enter **boot**.
3. Enter **describe**. The vital software data is displayed.
4. Press **Ctrl-p** to return to the OPCON (*) prompt.

Viewing Vital Hardware Data

Question How do I view vital hardware data?

Answer

1. Access the firmware main menu: During boot-up, press **F1** at the Prematurely terminate boot sequence prompt.
2. Select **4. Utilities**.
3. Select **9. View or Set Vital Product Data**.
4. Select **Hardware Vital Product Data**. The vital hardware data is displayed.
5. Return to the firmware main menu.
6. Press **F9** to load the operating software.

Adding an Adapter at Initial Configuration

Question How do I add an adapter to the software configuration when the IBM 2216 is being initially configured?

Answer First, perform installation of the 2216 and install any additional adapters into the 2216. (The section “2216 FRU Exchange” in the *IBM 2216 Service and Maintenance Manual* describes the removal and replacement procedure.

- When the 2216 is initially installed, it does not have any software configuration.
 - The operating system will put you at the Config only> prompt.
1. Enter **add device** *type of device*.

Note: The steps only create the interface. You still have to use the **net** command to configure characteristics unique to that interface (for example, T/R, Ethernet, PPP, FR, SDLC, X.25). You also need to use the **protocol** command to configure protocols on the interface.

For example, **add device token**, or **add device ?** to see a list of device choices.

2. Enter the device slot number (1–8).
3. If you are adding an interface on a single-port adapter, go to step 4 on page B-5. Otherwise, continue with this step.

Enter the port number (0–7, depending on the type of adapter).

The range of port numbers supported depends on the multi-port adapter type:

- For the Token-Ring (FC 2280) and Ethernet (FC 2281) adapters, port numbers 1 and 2 are supported.
- For the 8-port EIA-232E/V.24 (FC 2282) and 8-port X.21 adapters, port numbers 0–7 are supported.
- For the 6-port V.35/V.36 (FC 2290) adapter, port numbers 0–5 are supported.

4. Make a note of the interface number to which this port is assigned and the net number.

Repeat steps 1 to 4 if you have a multi-port adapter and you want to have more than one interface defined on that adapter.

Write the changes to save the configuration.

Reload the IBM 2216 to make the configuration changes active.

Adding an Adapter after Initial Configuration

Question How do I add an adapter after the IBM 2216 has been initially configured?

Answer First, perform hardware installation of the adapter. (The section “2216 FRU Exchange” in the *IBM 2216 Service and Maintenance Manual* describes the removal and replacement procedure.) Then:

1. Access the command line interface (* prompt).
2. Type **talk 6** and press **Enter** twice to reach the Config> prompt.
3. Enter **add device** *type of device*.

For example, **add device x21**, or **add device ?** to see a list of device choices.

The following two steps do not apply when a dial-circuit device is being added.

4. Enter the device slot number (1–8).
5. If you are adding an interface on a single-port adapter, go to step 6. Otherwise, continue with this step.

Enter the port number (0–7, depending on the type of adapter).

The range of port numbers supported depends on the multi-port adapter type:

- For the Token-Ring (FC 2280) and Ethernet (FC 2281) adapters, port numbers 1 and 2 are supported.
 - For the 8-port EIA-232E/V.24 (FC 2282) and 8-port X.21 adapters, port numbers 0–7 are supported.
 - For the 6-port V.35/V.36 (FC 2290) adapter, port numbers 0–5 are supported.
6. Make a note of the interface number to which this port is assigned and the net number.
 7. Enter **net** *net number* to enable you to configure interface-unique characteristics.
 8. Enter **exit** after configuring the interface.
 9. Use the **protocol** command to configure protocols on the interface.
 10. Enter **write** to save your changes.
 11. Press **Ctrl-p** to return to the OPCON (*) prompt.
 12. Use the **activate** command within **talk 5** to bring the new interface online to the network without rebooting the box. There are restrictions to this capability. See the “Configuring Spare Interfaces” heading in the *Multiprotocol Access Services Software User’s Guide*.

Running Quick Configuration

Question How do I run the Quick Configuration program?

Answer First, make sure each adapter has been “added” (see Adding an Adapter at Initial Configuration). Then, at the `Config (only)` or `Config>` prompt, enter **qc**.

Disabling an Adapter Port

Question How do I disable a configured adapter port to remove the adapter from the software configuration?

Answer

1. Access the command line interface (* prompt).
2. Type **talk 6** and press **Enter** twice to reach the `Config>` prompt.
3. Enter **list device**.
4. Make a note of the interface number of the adapter you wish to disable.
5. Enter **disable interface** *interface number*.
6. Enter **write** to save your changes. The next time that the 2216 is rebooted the configuration changes become active.

For details of this procedure, refer to the *Multiprotocol Access Services Software User's Guide*.

Enabling an Adapter Port

Question How do I enable a configured adapter port that was disabled using **disable interface** (in “Disabling an Adapter Port”)?

Use this procedure to enable the port the next time that you reboot the 2216.

Answer

1. Access the command line interface (* prompt).
2. Type **talk 6** and press **Enter** twice to reach the `Config>` prompt.
3. Enter **list device**.
4. Make a note of the interface number of the adapter you wish to enable.
5. Enter **enable interface** *interface number*.
6. Enter **write** to save your changes. The next time that the 2216 is rebooted the configuration changes become active.

For details of this procedure, refer to the *Multiprotocol Access Services Software User's Guide*.

Suspend Traffic on an Adapter Port

Question How do I disable a configured adapter port to remove or test an adapter?

Answer

1. Access the command line interface (* prompt).
2. Type **talk 5** and press **Enter** twice to reach the + prompt.

3. Enter the **configuration** command.
4. Make a note of the interface net number of the adapter that you want to disable.
5. Enter **disable interface** *interface net number*.
6. Press the **Ctrl-p** keys to return to the * prompt.

Resume Traffic on an Adapter Port

Question How do I enable a configured adapter port (that was disabled using the **talk 5 disable** command in “Suspend Traffic on an Adapter Port” on page B-6) to resume traffic?

Answer

1. Access the command line interface (* prompt).
2. Type **talk 5** and press **Enter** twice to reach the + prompt.
3. Enter the **configuration** command.
4. Make a note of the interface number of the adapter you wish to enable.
5. Enter **test** *interface number*.

Note: If you use the **test** command to enable an interface that has been configured at the Config> prompt (from **talk 6**) as disabled, when you reboot the 2216 the interface will be disabled again.

Therefore, you should also use the Config> **enable interface** command to ensure that the interface is enabled the next time a reboot does occur.

For details of this procedure, refer to the *Multiprotocol Access Services Software User's Guide*.

Removing and Deleting an Adapter

Question How do I remove and delete an adapter from the configuration?

Answer

1. Access the command line interface (* prompt).
2. Type **talk 6** and press **Enter** twice to reach the Config> prompt.
3. Enter **list device**.
4. Write down the interface number of the adapter that you wish to delete.

Note: If you are removing a multi-port adapter, then you need to record the interface number of all interfaces configured for that adapter.

5. Enter **delete interface** *interface number*.
6. At the Are you sure? prompt, enter **y**.
7. Enter **write** to save your changes.
8. Reload the IBM 2216 to make the configuration changes active.

For details of this procedure, refer to the *Multiprotocol Access Services Software User's Guide*.

Running Diagnostics

Question How are diagnostics run on a particular adapter?

Answer Refer to the *IBM 2216 Maintenance Guide*.

Up-to-Date IBM 2216 Information

Question How can I find out the most current information about the IBM 2216?

Answer Point your web browser to
<http://www.networking.ibm.com/216/216prod.html>

Disabling Interfaces that Have WAN Reroute Enabled

Question How do I ensure that WAN Reroute does not try to automatically enable an alternate interface that is on an adapter about to be removed?

Answer

1. Access the command line interface (the * prompt).
2. Type **talk 5** and press **Enter** twice to reach the + (monitoring) prompt.
3. Type **disable slot slot#** or **disable interface#** for each interface on the adapter. For example:

```
+ disable slot 4
```

```
Interface 4 is enabled as a WAN Reroute alternate circuit and should be disabled as an alternate circuit if you will be removing the adapter
```

```
Do you want to disable WAN Reroute on this interface? (Yes, No): [No] Yes
```

```
Interface 4 has been disabled as a WAN Reroute alternate circuit
```

```
(adapter is removed and replaced)
```

Enabling WAN Reroute after You Have Disabled it

Question How do I enable WAN Reroute to automatically enable an alternate interface that is on an adapter that has been replaced?

Answer

1. Access the command line interface (the * prompt).
2. Type **talk 5** and press **Enter** twice to reach the + (monitoring) prompt.
3. Type **enable slot slot#** to start a self-test for each interface on the adapter **or** type **test interface#** for each interface that you want to bring up.

If you start a self-test for an alternate interface and the self-test is successful, the alternate interface will remain up even though it may not be needed to back-up a primary interface. If this happens, you can issue the **talk 5 disable interface#** command to put the alternate interface back into the standby (disabled) state.

The following is a sample:

```
+ enable slot 4
```

```
Interface 4 is configured as a WAN Reroute alternate circuit.  
Do you want to enable WAN Reroute on this interface? (Yes, No):[No] Yes
```

```
Interface 4 is enabled as a WAN Reroute alternate circuit.  
Are you sure that you want to test this interface? (Yes, No): [No] Yes  
Testing net 4 ATM/0...successful  
+
```

Remote File Download

Question How do I download a configuration file to the 2216 using the Firmware Menu System?

Answer Use the Systems Management Services.

1. Using a local console, select **4. Disable Unattended Mode** from the Systems Management Utilities menu in the firmware to put the 2216 in ATTENDED mode. (Be sure to remember the password.)
2. To put the 2216 into the correct monitor mode for the remote console that is going to be used, reboot the 2216 and enter **Y** at the DO YOU WANT TO CHANGE THE MONITOR TYPE? prompt. Select the number next to the option for the Monitor type.
3. Remove the local console connection and reboot the 2216 again. Do a hardware reset to put the 2216 in ATTENDED mode. (Do not use the **reload** command.)
4. Wait at least 90 seconds for the 2216 to reach the POWER-ON PASSWORD after rebooting before attempting to remotely connect to the 2216.
5. Dial in to the 2216's PCMCIA modem with a TTY console. The console settings must be:
 - Speed = 19200 bps
 - Data bits = 8
 - Parity = No
 - Stop bits = 1
6. Once the connection is established, type in the password and press **Enter**. The password will not be displayed, but you should get an * on your screen for every character that you enter.
7. Press **F1** to terminate the boot sequence and enter the firmware Systems Management Services menu.
8. Select **4. Utilities** from the Systems Management Services menu.
9. Select **12. Change Management** from the Systems Management Utilities menu.
10. For MODEM: Configuration file must be on remote console, but no IP addresses are needed.
 - a. Select **12. Xmodem software** from the Change Management Software Control menu.
 - b. Select **1. Config** from the Select Type dialog box.

- c. Select the Bank to send the configuration file to from the Select Bank dialog box.
 - d. Select the config # to send the configuration file to from the Select Config dialog box.
 - e. When the BEGIN FILE TRANSFER dialog box closes, use your Xmodem software to transfer the files. For example, with PROCOMM:
 - Press the PAGE UP key when the dialog box disappears.
 - Press X for xmodem mode.
 - Type in the path and file name of the configuration you are going to transfer to the 2216.
 - Press ENTER.
11. For TFTP: You must have a PCMCIA networking card in the PCMCIA slot before booting the 2216 and be connected to a network that has the configuration file you are going to transfer to the 2216.
- Note:** IP addresses need to be set up on the PCMCIA slot using the System Management Utilities menu and select **11. Remote Initial Program Load Setup** before a TFTP can be done.
- a. Select **10. TFTP software** from the Change Management Software Control menu.
 - b. Select **1. Config** from the Select Type dialog box.
 - c. Select the Bank to send the configuration file to from the Select Bank dialog box.
 - d. Select the config # to send the configuration file to from the Select Config dialog box.
 - e. Type in the path and name of the Configuration file to be downloaded onto the 2216 and press **Enter**.

Spare Interfaces

Question Can I move traffic from a defective adapter to another adapter without restarting the 2216?

Answer Yes. Use the spare interface function of the 2216. See "Configuring Spare Interfaces" in the *Multiprotocol Access Services Software User's Guide*.

Appendix C. Notices

References in this publication to IBM products, programs, or services do not imply that IBM intends to make these available in all countries in which IBM operates. Any reference to an IBM product, program, or service is not intended to state or imply that only IBM's product, program, or service may be used. Subject to IBM's valid intellectual property, or other legally protectable rights, any functionally equivalent product, program, or service that does not infringe any of IBM's intellectual property rights may be used instead of the IBM product, program, or service. The evaluation and verification of operation in conjunction with other products, except those expressly designated by IBM, are the user's responsibility.

IBM may have patents or pending patent applications covering subject matter in this document. The furnishing of this document does not give you any license to these patents. You can send license inquiries, in writing, to:

IBM Director of Licensing
IBM Corporation
500 Columbus Avenue
Thornwood, NY 10594 USA

Notice to Users of Online Versions of This Book

For online versions of this book, we authorize you to:

- Copy, modify, and print the documentation contained on the media, for use within your enterprise, provided you reproduce the copyright notice, all warning statements, and other required statements on each copy or partial copy.
- Transfer the original unaltered copy of the documentation when you transfer the related IBM product (which may be either machines you own, or programs, if the program's license terms permit a transfer). You must, at the same time, destroy all other copies of the documentation.

You are responsible for payment of any taxes, including personal property taxes, resulting from this authorization.

THERE ARE NO WARRANTIES, EXPRESS OR IMPLIED, INCLUDING THE WARRANTIES OF MERCHANTABILITY AND FITNESS FOR A PARTICULAR PURPOSE.

Some jurisdictions do not allow the exclusion of implied warranties, so the above exclusion may not apply to you.

Your failure to comply with the terms above terminates this authorization. Upon termination, you must destroy your machine-readable documentation.

Electronic Emission Notices

Federal Communications Commission (FCC) Class A Statement

Note: This equipment has been tested and found to comply with the limits for a Class A digital device, pursuant to Part 15 of the FCC Rules. These limits are designed to provide reasonable protection against harmful interference when the equipment is operated in a commercial environment. This equipment generates, uses, and can radiate radio frequency energy and, if not installed and used in accordance with the instruction manual, may cause harmful interference to radio communications. Operation of this equipment in a residential area is likely to cause harmful interference, in which case the user will be required to correct the interference at his own expense.

IBM is not responsible for any radio or television interference caused by unauthorized changes or modifications to this equipment. Unauthorized changes or modifications could void the user's authority to operate the equipment.

This device complies with Part 15 of the FCC Rules. Operation is subject to the following two conditions: (1) this device may not cause harmful interference, and (2) this device must accept any interference received, including interference that may cause undesired operation.

Industry Canada Class A Emission Compliance Statement

This Class A digital apparatus meets the requirements of the Canadian Interference-Causing Equipment Regulations.

Avis de conformité aux normes d'Industrie Canada

Cet appareil numérique de la classe A respecte toutes les exigences du Règlement sur le matériel brouilleur du Canada.

Japanese Voluntary Control Council for Interference (VCCI) Statement

This is a Class A product based on the standard of the Voluntary Control Council for Interference by Information Technology Equipment (VCCI). If this equipment is used in a domestic environment, radio disturbance may arise. When such trouble occurs, the user may be required to take corrective actions.

この装置は、情報処理装置等電波障害自主規制協議会（VCCI）の基準に基づくクラスA情報技術装置です。この装置を家庭環境で使用すると電波妨害を引き起こすことがあります。この場合には使用者が適切な対策を講ずるよう要求されることがあります。

CISPR22 Compliance Statement

This product has been tested and found to comply with the limits for Class A Information Technology Equipment according to CISPR 22/European Standard EN 55022. The limits for Class A equipment were derived for commercial and industrial environments to provide reasonable protection against interference with licensed communication equipment.

Attention: This is a Class A product. In a domestic environment this product may cause radio interference in which case the user may be required to take adequate measures.

Taiwanese Class A Warning Statement

警告使用者：
這是甲類的資訊產品，在
居住的環境中使用時，可
能會造成射頻干擾，在這
種情況下，使用者會被要
求採取某些適當的對策。

European Union (EU) Mark of Conformity Statement

This product is in conformity with the protection requirements of EC Council Directive 89/336/EEC on the approximation of the laws of the Member States relating to electromagnetic compatibility. IBM cannot accept responsibility for any failure to satisfy the protection requirements resulting from a non-recommended modification of the product, including the fitting of non-IBM option cards.

The product bears the Telecom CE mark (CE 168 X) for ISDN Basic Rate complying with I-CTR3 (Bridging measures) as per the European directive 91/263/EEC (TTE directive). The product bears the Telecom CE mark (CE 168 X) for: V.24/V.28,V36 and X.21 electrical interfaces complying with NET 1 and with NET 2 physical level. ISDN Basic Rate complying with I-CTR3 (Bridging measures) as per the European directive 91/263/EEC (TTE directive).

Attention:

This is a Class A product. In a domestic environment this product may cause radio interference in which case the user may be required to take adequate measures.

Zulassungsbescheinigung laut dem Deutschen Gesetz über die elektromagnetische Verträglichkeit von Geräten (EMVG) vom 30. August 1995 (bzw. der EMC EG Richtlinie 89/336)

Dieses Gerät ist berechtigt in Übereinstimmung mit dem Deutschen EMVG das EG-Konformitätszeichen - CE - zu führen.

Verantwortlich für die Konformitätserklärung nach Paragraph 5 des EMVG ist die IBM Deutschland Informationssysteme GmbH, 70548 Stuttgart.

Informationen in Hinsicht EMVG Paragraph 3 Abs. (2) 2:

Das Gerät erfüllt die Schutzanforderungen nach EN 50082-1 und EN 55022 Klasse A.

EN 55022 Klasse A Geräte müssen mit folgendem Warnhinweis versehen werden: "Warnung: dies ist eine Einrichtung der Klasse A. Diese Einrichtung kann im Wohnbereich Funkstörungen verursachen; in diesem Fall kann vom Betreiber verlangt werden, angemessene Maßnahmen durchzuführen und dafür aufzukommen."

EN 50082-1 Hinweis: "Wird dieses Gerät in einer industriellen Umgebung betrieben (wie in EN 50082-2 festgelegt), dann kann es dabei eventuell gestört werden. In solch einem Fall ist der Abstand bzw. die Abschirmung zu der industriellen Störquelle zu vergrößern."

Anmerkung: Um die Einhaltung des EMVG sicherzustellen sind die Geräte, wie in den IBM Handbüchern angegeben, zu installieren und zu betreiben.

Telecommunication Notices

FCC Part 68 Compliance Information:

Features and optional adapters for the IBM 2216 comply with Part 68 of the FCC rules. The label included on the adapter tray contains, among other information, the FCC registration number and Ringer Equivalence Number (REN), if applicable for this equipment. If requested, provide this information to your telephone company.

The features and adapters included are:

1-Port ISDN PRI (T1/J1) Adapter LIC 283 with interface code 04DU9-1SN, service code 6.0N and jack type RJ48C.

4-port ISDN PRI/Channelized (T1/J1) Daughter Card with interface code 04DU9-1SN, service code 6.0N and jack type RJ48C.

The REN is useful to determine the quantity of devices you may connect to your telephone line and still have those devices ring when your number is called. In most, but not all areas, the sum of the RENs of all devices should not exceed five (5.0). To be certain of the number of devices you may connect to your line, as determined by the REN, you should call your local telephone company to determine the maximum REN for your calling area.

If the IBM 2216 causes harm to the telephone network, the Telephone Company may discontinue your service temporarily. If possible, they will notify you in advance. But if advance notice isn't practical, you will be notified as soon as possible. You will be advised of your right to file a complaint with the FCC.

Your telephone company may make changes in its facilities, equipment, operations, or procedures that could affect the proper operation of your equipment. If they do, you will be given advance notice so as to give you an opportunity to maintain uninterrupted service.

If trouble is experienced with this equipment, for repair or warranty information, in the United States, call IBM at **1-800-IBM-SERV**. In Canada, call IBM at **1-800-465-6600**.

No repairs can be performed by the customer.

Industry Canada Information:

NOTICE: The Industry Canada label identifies certified equipment. This certification means that the equipment meets certain telecommunications network protective, operational and safety requirements. Industry Canada does not guarantee the equipment will operate to the user's satisfaction.

Before installing this equipment, users should ensure that it is permissible to be connected to the facilities of the local telecommunications company. The equipment must also be installed using an acceptable method of connection. In some cases, the company's inside wiring associated with a single line individual service may be extended by means of a certified connector assembly (telephone extension cord). The customer should be aware that compliance with the above conditions may not prevent degradation of service in some situations.

Repairs to certified equipment should be made by an authorized Canadian maintenance facility designated by the supplier. Any repairs or alterations made by the user to this equipment, or equipment malfunctions, may give the telecommunications company cause to request the user to disconnect the equipment.

Users should ensure for their own protection that the electrical ground connections of the power utility, telephone lines and internal metallic water pipe system, if present, are connected together. This precaution may be particularly important in rural areas.

CAUTION: Users should not attempt to make such connections themselves, but should contact the appropriate electrical inspection authority, or electrician, as appropriate.

AVIS : L'étiquette d'Industrie Canada permet d'identifier un équipement homologué. Cette homologation signifie que cet équipement satisfait certaines exigences en matière de protection, d'exploitation et de sécurité du réseau de télécommunications. Industrie Canada n'offre aucune garantie que le fonctionnement de cet équipement soit à la satisfaction de l'utilisateur.

Avant d'installer cet équipement, l'utilisateur doit s'assurer qu'il a la permission de le raccorder aux installations de l'entreprise de télécommunications. L'installation de cet équipement doit aussi se faire selon un mode de raccordement acceptable. Dans certains cas, le câblage interne de l'entreprise associé au service individuel offert par une ligne d'abonné peut être prolongé au moyen d'un connecteur homologué (prolongateur de téléphone). Le client devrait être informé que la conformité de son équipement aux conditions susmentionnées n'est pas une prévention contre la dégradation du service dans certaines situations.

Toute réparation d'un équipement homologué devrait être effectuée par un service de maintenance canadien autorisé qui a été désigné par le fournisseur. Toute réparation ou modification d'équipement faite par l'utilisateur, ou tout mauvais fonctionnement, pourrait entraîner la déconnexion de cet équipement par l'utilisateur à la demande de l'entreprise de télécommunications.

Pour sa protection personnelle, l'utilisateur devrait s'assurer que les mises à la terre des services publics électriques, des lignes téléphoniques et du système interne des canalisations d'eau à tuyaux métalliques, advenant leur présence, sont interconnectées. Dans les zones rurales, il s'agit-là d'une précaution particulièrement importante à prendre.

ATTENTION : Toute tentative de connexion par l'utilisateur est à déconseiller. Il est préférable de communiquer avec le responsable de l'inspection en électricité ou un électricien, selon le cas.

United Kingdom Compliance Statement

STATEMENT OF COMPLIANCE

The United Kingdom Telecommunications Act 1984. This equipment is approved under
General Approval Number NS/G/1234/J/100003

for indirect connections to the public telecommunications systems in the United
Kingdom.

Trademarks

The following terms are trademarks of the IBM Corporation in the United States or other countries or both:

ESCON
IBM

Nways
NetView

OS/2
Presentation Manger

Other company, product, and service names may be trademarks or service marks of others.

Appendix D. Safety Information

 **Danger:** Before you begin to install this product, read the safety information in *Caution: Safety Information—Read This First*, SD21-0030. This booklet describes safe procedures for cabling and plugging in electrical equipment.

 **Gevaar:** Voordat u begint met de installatie van dit produkt, moet u eerst de veiligheidsinstructies lezen in de brochure *PAS OP! Veiligheidsinstructies—Lees dit eerst*, SD21-0030. Hierin wordt beschreven hoe u elektrische apparatuur op een veilige manier moet bekabelen en aansluiten.

 **Danger:** Avant de procéder à l'installation de ce produit, lisez d'abord les consignes de sécurité dans la brochure *ATTENTION: Consignes de sécurité—A lire au préalable*, SD21-0030. Cette brochure décrit les procédures pour câbler et connecter les appareils électriques en toute sécurité.

 **Perigo:** Antes de começar a instalar este produto, leia as informações de segurança contidas em *Cuidado: Informações Sobre Segurança—Leia Isto Primeiro*, SD21-0030. Esse folheto descreve procedimentos de segurança para a instalação de cabos e conexões em equipamentos elétricos.



危險：安裝本產品之前，請先閱讀
"Caution: Safety Information--Read
This First" SD21-0030 手冊中所提
供的安全注意事項。這本手冊將會說明
使用電器設備的纜線及電源的安全程序。



Opasnost: Prije nego što počnete sa instalacijom produkta, pročitate naputak o pravilima o sigurnom rukovanju u
Upozorenje: Pravila o sigurnom rukovanju - Prvo pročitaj ovo, SD21-0030. Ovaj priručnik opisuje sigurnosne postupke za priključivanje kabela i priključivanje na električno napajanje.





Upozornění: než zahájíte instalaci tohoto produktu, přečtěte si nejprve bezpečnostní informace v pokynech „Bezpečnostní informace“ č. 21-0030. Tato brožurka popisuje bezpečnostní opatření pro kabeláž a zapojení elektrického zařízení.





Fare! Før du installerer dette produkt, skal du læse sikkerhedsforskrifterne i *NB: Sikkerhedsforskrifter—Læs dette først* SD21-0030. Vejledningen beskriver den fremgangsmåde, du skal bruge ved tilslutning af kabler og udstyr.

 **Gevaar** Voordat u begint met het installeren van dit produkt, dient u eerst de veiligheidsrichtlijnen te lezen die zijn vermeld in de publikatie *Caution: Safety Information - Read This First*, SD21-0030. In dit boekje vindt u veilige procedures voor het aansluiten van elektrische apparatuur.

 **VAARA:** Ennen kuin aloitat tämän tuotteen asennuksen, lue julkaisussa *Varoitus: Turvaohjeet—Lue tämä ensin*, SD21-0030, olevat turvaohjeet. Tässä kirjassessa on ohjeet siitä, miten sähkölaitteet kaapeloidaan ja kytketään turvallisesti.

 **Danger :** Avant d'installer le présent produit, consultez le livret *Attention : Informations pour la sécurité — Lisez-moi d'abord* SD21-0030, qui décrit les procédures à respecter pour effectuer les opérations de câblage et brancher les équipements électriques en toute sécurité.

 **Vorsicht:** Bevor mit der Installation des Produktes begonnen wird, die Sicherheitshinweise in *Achtung: Sicherheitsinformationen—Bitte zuerst lesen*, &ibm; Form SD21-0030. Diese Veröffentlichung beschreibt die Sicherheitsvorkehrungen für das Verkabeln und Anschließen elektrischer Geräte.

 **Vigyázat:** Mielőtt megkezdi a berendezés üzembe helyezését, olvassa el a *Caution: Safety Information— Read This First*, SD21-0030 könyvecskében leírt biztonsági információkat. Ez a könyv leírja, milyen biztonsági intézkedéseket kell megtenni az elektromos berendezés huzalozásakor illetve csatlakoztatásakor.

 **Pericolo:** prima di iniziare l'installazione di questo prodotto, leggere le informazioni relative alla sicurezza riportate nell'opuscolo *Attenzione: Informazioni di sicurezza — Prime informazioni da leggere* in cui sono descritte le procedure per il cablaggio ed il collegamento di apparecchiature elettriche.



危険： 導入作業を開始する前に、安全に関する小冊子SD21-0030 の「最初にお読みください」(Read This First)の項をお読みください。
この小冊子は、電気機器の安全な配線と接続の手順について説明しています。



위험: 이 제품을 설치하기 전에 반드시 "주의: 안전 정보-시작하기 전에" (SD21-0030) 에 있는 안전 정보를 읽으십시오.



Fare: Før du begynner å installere dette produktet, må du lese sikkerhetsinformasjonen i *Advarsel: Sikkerhetsinformasjon — Les dette først*, SD21-0030 som beskriver sikkerhetsrutinene for kabling og tilkobling av elektrisk utstyr.



Uwaga:

Przed rozpoczęciem instalacji produktu należy zapoznać się z instrukcją: "Caution: Safety Information - Read This First", SD21-0030.

Zawiera ona warunki bezpieczeństwa przy podłączaniu do sieci elektrycznej i eksploatacji.



Perigo: Antes de iniciar a instalação deste produto, leia as informações de segurança *Cuidado: Informações de Segurança — Leia Primeiro*, SD21-0030. Este documento descreve como efectuar, de um modo seguro, as ligações eléctricas dos equipamentos.



ОСТОРОЖНО: Прежде чем устанавливать этот продукт, прочтите Инструкцию по технике безопасности в документе "Внимание: Инструкция по технике безопасности -- Прочсть в первую очередь", SD21-0030. В этой брошюре описаны безопасные способы каблирования и подключения электрического оборудования.



Nebezpečnostvo: Pred inštaláciou výrobku si prečítajte bezpečnosté predpisy v

Výstraha: Bezpečnosté predpisy - Prečítaj ako prvé, SD21-0030. V tejto brožúrke sú opísané bezpečnosté postupy pre pripojenie elektrických zariadení.



Pozor: Preden začnete z instalacijo tega produkta preberite poglavje: "Opozorilo: Informacije o varnem rokovanju-preberi pred uporabo," SD21-0030. To poglavje opisuje pravilne postopke za kabliranje,



Peligro: Antes de empezar a instalar este producto, lea la información de seguridad en *Atención: Información de Seguridad — Lea Esto Primero*, SD21-0030. Este documento describe los procedimientos de seguridad para cablear y enchufar equipos eléctricos.



Varning — livsfara: Innan du börjar installera den här produkten bör du läsa säkerhetsinformationen i dokumentet *Varning: Säkerhetsföreskrifter— Läs detta först*, SD21-0030. Där beskrivs hur du på ett säkert sätt ansluter elektrisk utrustning.



危險：

開始安裝此產品之前，請先閱讀安全資訊。

注意：

請先閱讀 - 安全資訊 SD21-0030

此冊子說明插接電器設備之電纜線的安全程序。

Caution Notices

CAUTION

A fully populated IBM 2216 weighs about 43.1 kg (95 lb).

LET OP:

Als alle voorzieningen geïnstalleerd zijn, weegt de IBM 2216 ongeveer 43,1 kg.

CUIDADO:

Um dispositivo IBM 2216 totalmente populado pesa cerca de 43,1 kg (95 lb).

Pas på!

En fuldt udbygget IBM 2216 vejer ca. 43,1 kg.

ATTENTION

Un IBM 2216 entièrement équipé pèse environ 43,1 kg.

ACHTUNG

Eine voll bestückte IBM 2216 wiegt ungefähr 43.1 kg.

ATTENZIONE:

Un IBM 2216 cui sono collegate tutte le unità pesa circa 43,1 kg.

CUIDADO:

Um IBM 2216 totalmente preenchido pesa cerca de 43 kg.

Precaució

Un IBM 2216 completamente equipado pesa alrededor de 43.1 kg (95 lb).

VARNING:

En fullt utbyggd IBM 2216 väger ca 43 kg.

ADVARSEL

En IBM 2216 som er fullt utstyrt, veier ca. 43 kg.

危険:

IBM 2216は装備により約43kgの重さがあります。

POZOR:

Plně osazená IBM 2216 váží zhruba 43,1 kg.

危険!

欲防止電信網路上的電壓造成損壞，除非法律明文禁止，否則在從地面切斷通信單元前，請先切斷所有的電信網路線路。

注意:

一台配置完整的 IBM 2216 重约 43.1 kg (95 lb)。

VIGYÁZAT!

A teljesen kiépített IBM 2216 berendezés tömege kb. 43,1 kg (95 lb)

При полной комплектации IBM 2216 весит около 45 кг.

VÝSTRAHA

Zariadenie IBM 2216 v plnej výbave váži cca 43.1 kg (95 lb).

UWAGA

Całkowicie wypełnione urządzenie IBM 2216 waży około 43.1 kg.

Index

A

- access methods, physical 3-1
- accessing the IBM 2216 3-1
- adapter card status 2-3
- adapter plugging A-1
- ASCII terminal 3-3
- ASCII terminal, connection to 2216 3-3
- assumptions A-1
- attributes for ASCII terminal 3-3

B

- backup configuration 4-2

C

- change management 3-4
- change management function 3-4
- common tasks B-1
- configuration 4-1
 - router, setting up 4-1
 - setting up the router 4-1
- configuration, initial 4-1
- corrections, documentation ix

F

- factory plugging defaults A-1
- file, backup 4-2
- fixes ix
- function keys 3-4
- functions 3-4

H

- help ix
- http sites ix

I

- initial configuration 4-1
 - router, setting up 4-1
 - setting up the router 4-1
- Installing the 2216 1-1

L

- local access to 2216 3-3

M

- managing configuration problems 4-2

- methods of access 3-1

P

- performing the initial configuration 4-1
- physical access methods 3-1
- plugging defaults A-1
- plugging sequences A-1
- power supply status 2-3
- problem solving 2-1
- problems in configuration 4-2

S

- safety notices IBM 2216 D-4
 - translated D-4
- settings, ASCII terminal 3-3
- setup attributes, ASCII terminal 3-3
- slots and adapters A-1
- software and configuration change management 3-4
- system card status 2-3

T

- tasks, common B-1
- terminal settings 3-3
- terminal, ASCII 3-3
- terminal, attachment to 2216 3-3
- translated safety notices D-1

U

- updates ix

W

- web sites ix

Communicating Your Comments to IBM

2216 Nways Multiaccess Connector
Installation
and
Initial Configuration Guide
Publication No. GA27-4106-02

If you especially like or dislike anything about this book, please use one of the methods listed below to send your comments to IBM. Whichever method you choose, make sure you send your name, address, and telephone number if you would like a reply.

Feel free to comment on specific errors or omissions, accuracy, organization, subject matter, or completeness of this book. However, the comments you send should pertain to only the information in this manual and the way in which the information is presented. To request additional publications, or to ask questions or make comments about the functions of IBM products or systems, you should talk to your IBM representative or to your IBM authorized remarketer.

When you send comments to IBM, you grant IBM a nonexclusive right to use or distribute your comments in any way it believes appropriate without incurring any obligation to you.

If you are mailing a readers' comment form (RCF) from a country other than the United States, you can give the RCF to the local IBM branch office or IBM representative for postage-paid mailing.

- If you prefer to send comments by mail, use the RCF at the back of this book.
- If you prefer to send comments by FAX, use this number:
1-800-253-3520

Make sure to include the following in your note:

- Title and publication number of this book
- Page number or topic to which your comment applies.

Readers' Comments — We'd Like to Hear from You

**2216 Nways Multiaccess Connector
Installation
and
Initial Configuration Guide
Publication No. GA27-4106-02**

Overall, how satisfied are you with the information in this book?

	Very Satisfied	Satisfied	Neutral	Dissatisfied	Very Dissatisfied
Overall satisfaction	<input type="checkbox"/>	<input type="checkbox"/>	<input type="checkbox"/>	<input type="checkbox"/>	<input type="checkbox"/>

How satisfied are you that the information in this book is:

	Very Satisfied	Satisfied	Neutral	Dissatisfied	Very Dissatisfied
Accurate	<input type="checkbox"/>	<input type="checkbox"/>	<input type="checkbox"/>	<input type="checkbox"/>	<input type="checkbox"/>
Complete	<input type="checkbox"/>	<input type="checkbox"/>	<input type="checkbox"/>	<input type="checkbox"/>	<input type="checkbox"/>
Easy to find	<input type="checkbox"/>	<input type="checkbox"/>	<input type="checkbox"/>	<input type="checkbox"/>	<input type="checkbox"/>
Easy to understand	<input type="checkbox"/>	<input type="checkbox"/>	<input type="checkbox"/>	<input type="checkbox"/>	<input type="checkbox"/>
Well organized	<input type="checkbox"/>	<input type="checkbox"/>	<input type="checkbox"/>	<input type="checkbox"/>	<input type="checkbox"/>
Applicable to your tasks	<input type="checkbox"/>	<input type="checkbox"/>	<input type="checkbox"/>	<input type="checkbox"/>	<input type="checkbox"/>

Please tell us how we can improve this book:

Thank you for your responses. May we contact you? Yes No

When you send comments to IBM, you grant IBM a nonexclusive right to use or distribute your comments in any way it believes appropriate without incurring any obligation to you.

Name

Address

Company or Organization

Phone No.



Fold and Tape

Please do not staple

Fold and Tape



NO POSTAGE
NECESSARY
IF MAILED IN THE
UNITED STATES

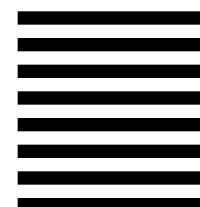

BUSINESS REPLY MAIL

FIRST-CLASS MAIL PERMIT NO. 40 ARMONK, NEW YORK

POSTAGE WILL BE PAID BY ADDRESSEE

IBM Corporation
Design & Information Development
Department CGF/Bldg. 656
PO Box 12195
Research Triangle Park, NC 27709-9990



Fold and Tape

Please do not staple

Fold and Tape



Part Number: 25L5044



Printed in the United States of America
on recycled paper containing 10%
recovered post-consumer fiber.

GA27-4106-02



25L5044

